

Technical Data Sheet



Material



SKYPET-BL-8050

Property	Unit	Value	Test Method
Intrinsic Viscosity	dL / g	0.80 ± 0.02	SK Chemicals Method
Melting Temperature	°C	245 ± 2	DSC
Density	g / cm ³	1.40 ± 0.01	ASTM D 1505
Bulk Density	kg / m ³	820 ~ 900	ASTM 1895
Acetaldehyde	ppm	1 MAX	SK Chemicals Method
Color b	-	1 MAX	SK Chemicals Method
Moisture	wt%	0.3 MAX	Karl-Fisher Method

Chemical Resistance	PET	
	RT	50 - 60 °C
Acetaldehyde, pure	-	-
Acetic acid 5%	G	-
Acetic acid 50%	F	N
Acetone, pure	N	N
Acetonitrile, pure	-	-
Ammonium acetate, saturated	-	-
Ammonium hydroxide 5%	F	N
Ammonium hydroxide 30%	N	N
Butyric acid, pure	N	N
Chloroform, pure	-	-
Chromic acid, 50%	-	-

E: Excellent **G:** Good **F:** Fair **N:** Not Recommended **-:** No Data

2

Material

Chemical Resistance	PET	
	RT	50 - 60 °C
Cyclohexane, pure	-	-
Dimethylsulfoxide, pure	N	N
Ether, pure	E	-
Ethyl alcohol, 40%	G	-
Ethyl alcohol, pure	G	-
Ethylene glycol, pure	E	-
Formaldehyde, 10%	E	-
Formaldehyde, 40%	-	-
Formic acid, 3%	-	-
Formic acid, 50%	-	-
Glutaraldehyde, pure	-	-
Glutaraldehyde, disinfectant	-	-
Glycerine, pure	E	-
Glycerole, pure	E	-
Hexane	-	-
Hydrochloric acid, 5%	E	-
Hydrochloric acid, 35%	F	N
Hydrogen peroxide, 3%	E	-
Hydrogen peroxide, 30%	E	-

E: Excellent **G:** Good **F:** Fair **N:** Not Recommended **-:** No Data

Material

Chemical Resistance	PET	
	RT	50 - 60 °C
Iso butyl alcohol, pure	-	-
Isopropanol, pure	-	-
Methyl alcohol, pure	G	-
Methyl ethyle ketone, pure	G	-
Nitric acid, 10%	G	-
Nitric acid, 70%	N	N
Phenol, liquid	N	N
Phosphoric acid, 5%	-	-
Phosphoric acid, 85%	-	-
Picric acid, pure	-	-
Potassium hydroxide, 1%	-	-
Potassium hydroxide, conc.	-	-
Sulfuric acid, 6%	E	-
Sulfuric acid, 98%	N	N
Trichloroacetic acids	-	-

E: Excellent **G:** Good **F:** Fair **N:** Not Recommended **-:** No Data

Material

Chemical Resistance	HDPE	
	RT	50 - 60 °C
Acetaldehyde, pure	G	G
Acetic acid 5%	E	E
Acetic acid 50%	E	E
Acetone, pure	N	N
Acetonitrile, pure	E	E
Ammonium acetate, saturated	E	E
Ammonium hydroxide 5%	E	E
Ammonium hydroxide 30%	E	E
Butyric acid, pure	F	F
Chloroform, pure	F	F
Chromic acid, 50%	E	E
Cyclohexane, pure	F	F
Dimethylsulfoxide, pure	E	E
Ether, pure	F	F
Ethyl alcohol, 40%	E	E
Ethyl alcohol, pure	E	E
Ethylene glycol, pure	E	E
Formaldehyde, 10%	E	E
Formaldehyde, 40%	E	E

E: Excellent **G:** Good **F:** Fair **N:** Not Recommended -: No Data

Material

Chemical Resistance	HDPE	
	RT	50 - 60 °C
Formic acid, 3%	E	E
Formic acid, 50%	E	E
Glutaraldehyde, pure	E	E
Glutaraldehyde, disinfectant	E	E
Glycerine, pure	E	E
Glycerole, pure	E	E
Hexane	N	N
Hydrochloric acid, 5%	E	E
Hydrochloric acid, 35%	E	E
Hydrogen peroxide, 3%	E	E
Hydrogen peroxide, 30%	E	E
Iso butyl alcohol, pure	E	E
Isopropanol, pure	E	E
Methyl alcohol, pure	E	E
Methyl ethyle ketone, pure	N	N
Nitric acid, 10%	E	E
Nitric acid, 70%	F	F
Phenol, liquid	N	B
Phosphoric acid, 5%	E	E

E: Excellent **G:** Good **F:** Fair **N:** Not Recommended **-:** No Data

Material

Chemical Resistance	HDPE	
	RT	50 - 60 °C
Phosphoric acid, 85%	E	E
Picric acid, pure	N	N
Potassium hydroxide, 1%	F	F
Potassium hydroxide, conc.	E	E
Sulfuric acid, 6%	E	E
Sulfuric acid, 98%	F	F
Trichloroacetic acids	F	F

E: Excellent **G:** Good **F:** Fair **N:** Not Recommended **-:** No Data

Irradiation

Product	Square Media Bottle 1000 ml, Art. 56000	
Lot No	S0110B12	(This Lot is used hereafter to demonstrate the irradiation process and results)
Dimension	410 x 310 x 470 mm	
Weight per unit	3.7 g	
Loading quantity	8 boxes	
Loading density	0.04 g/cm ³	
Process Parameter		
Set Master Time	4 min 31 sec	
Set Cycle	6	
Dosimeter	Harwell 4034 RED	
Dosimeter Batch	JT	

Results

1. Dose Measurement

Position	Dose Map	Location
D _{Min}	28.2	M5
D _{Max}	31.8	M8

2. Dose Uniformity Ratio

D_{Max} / D_{Min} : 31.8 kGy / 28.2 kGy = 1.13

Irradiation

3. Dose Distribution

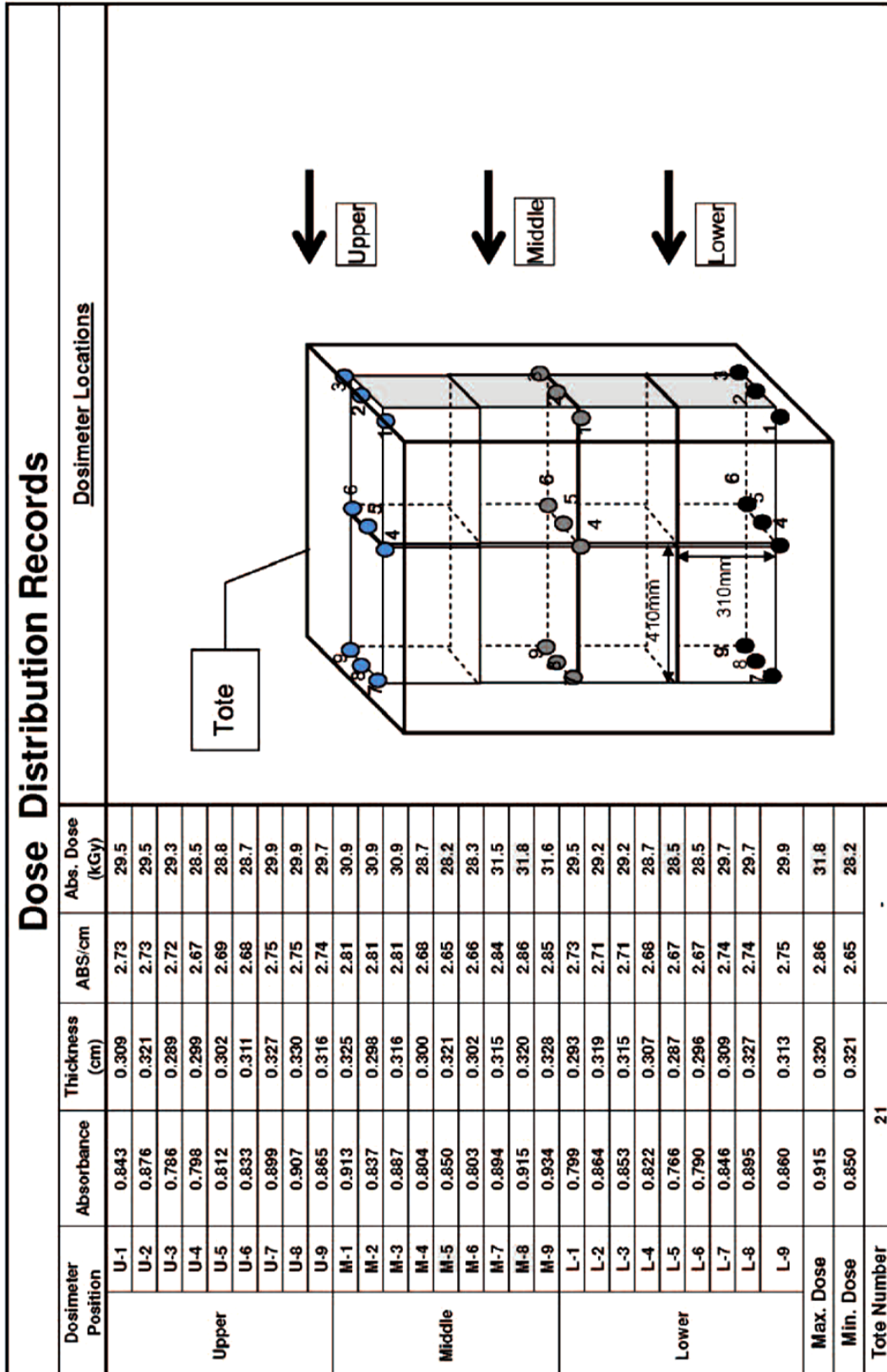

Irradiation

Master Process Specification				
Product	Square Media Bottle, 1000 ml		Specific Dose	
			Min: 25 kGy	Max: 40 kGy
Box information	Weight	Width	Length	Height
	3.7 g	410 mm	310 mm	470 mm
Loading Quantity	8 boxes	Total weight	29.6 g	
Product density	0.06 g/cm ³	Loading Density	0.04 g/cm ³	

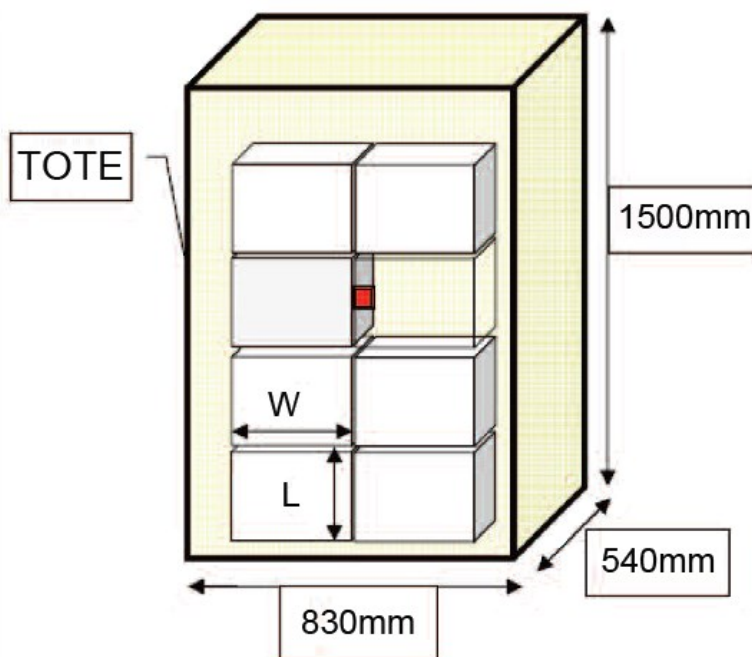

Routine Monitoring Position & Correlation Factor

Routine monitoring location (D_{Min}): M5

D_{Max} / D_{Min} ratio = 31.8 / 28.2 : 1.13

* Adherence of Dosimeter

One dosimeter is adhered at each position (1st, middle and last position), respectively, totally three. When partly loaded, only one dosimeter is adhered in maximum position.

Product Data

Dimensional Specification			
Normal Volume	125 ml	Height	103.7 ± 0.7 mm
Dimension	52.5 ± 0.5 mm	Weight	31.3 ± 0.5 g
Package Information			
Box Size	235 x 335 x 465 mm		
Amount / Box	96 units / box		
Amount / Pallet	65 boxes / pallet		

Drawings

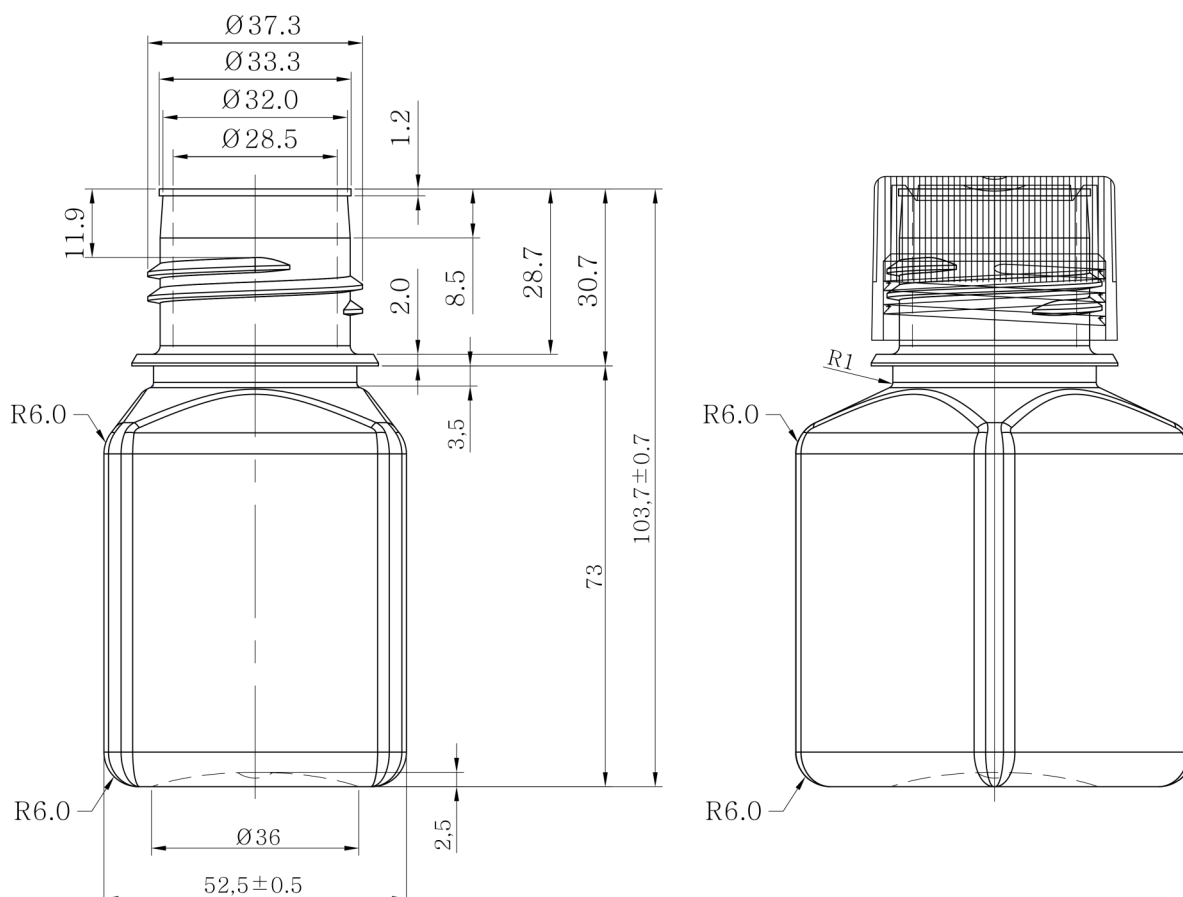

500ml, Art. 56500



Product Data

Dimensional Specification			
Normal Volume	500 ml	Height	172.0 ± 0.7 mm
Dimension	77.0 ± 1.0 mm	Weight	70.7 ± 0.5 g
Package Information			
Box Size	480 x 325 x 395 mm		
Amount / Box	48 units / box		
Amount / Pallet	48 boxes / pallet		

Drawings

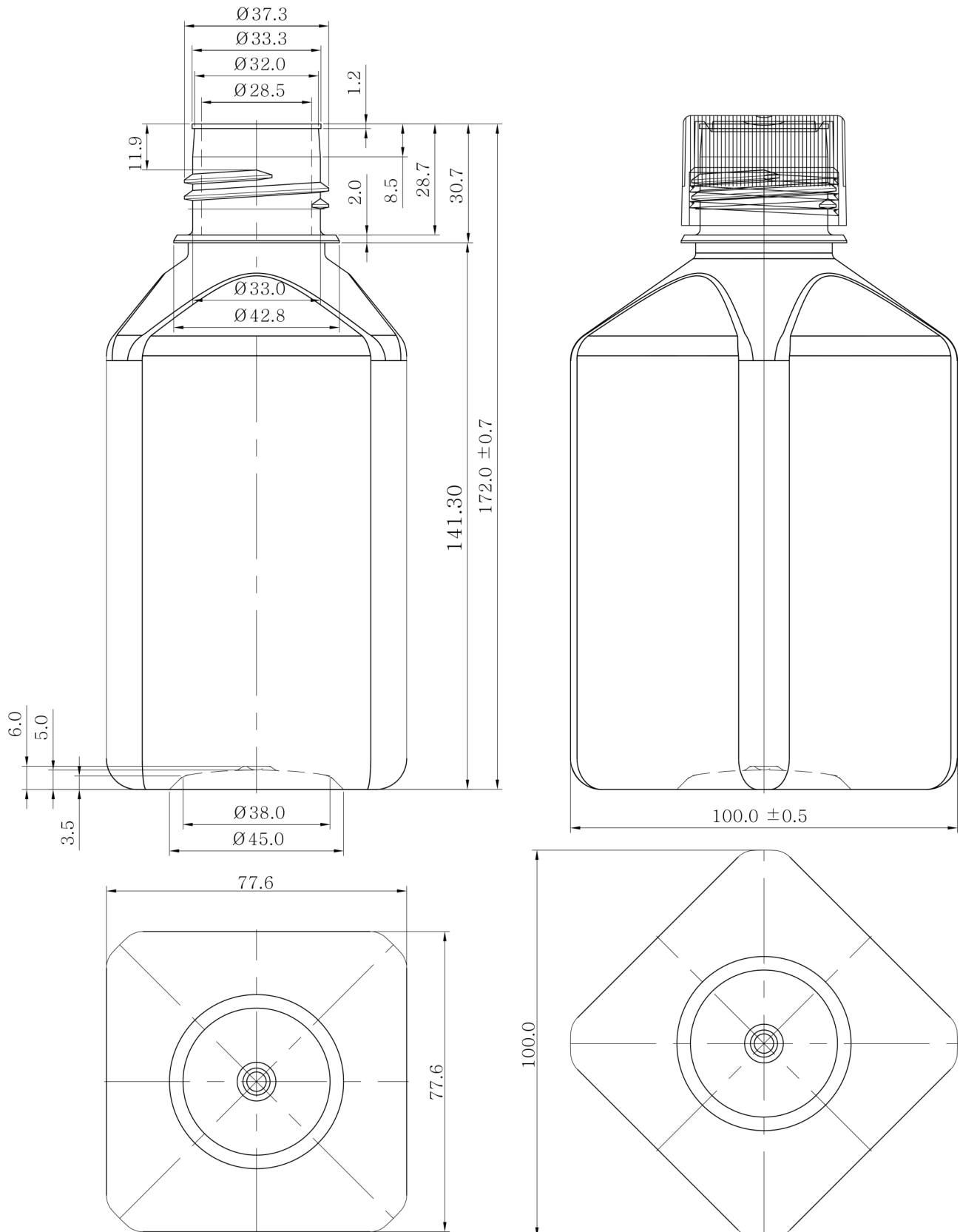

Product Data

Dimensional Specification			
Normal Volume	1000 ml	Height	213.0 ± 1.0 mm
Dimension	99.5 ± 1.0 mm	Weight	93.2 ± 1.0 g
Package Information			
Box Size	310 x 400 x 465 mm		
Amount / Box	24 units / box		
Amount / Pallet	45 boxes / pallet		

Drawings

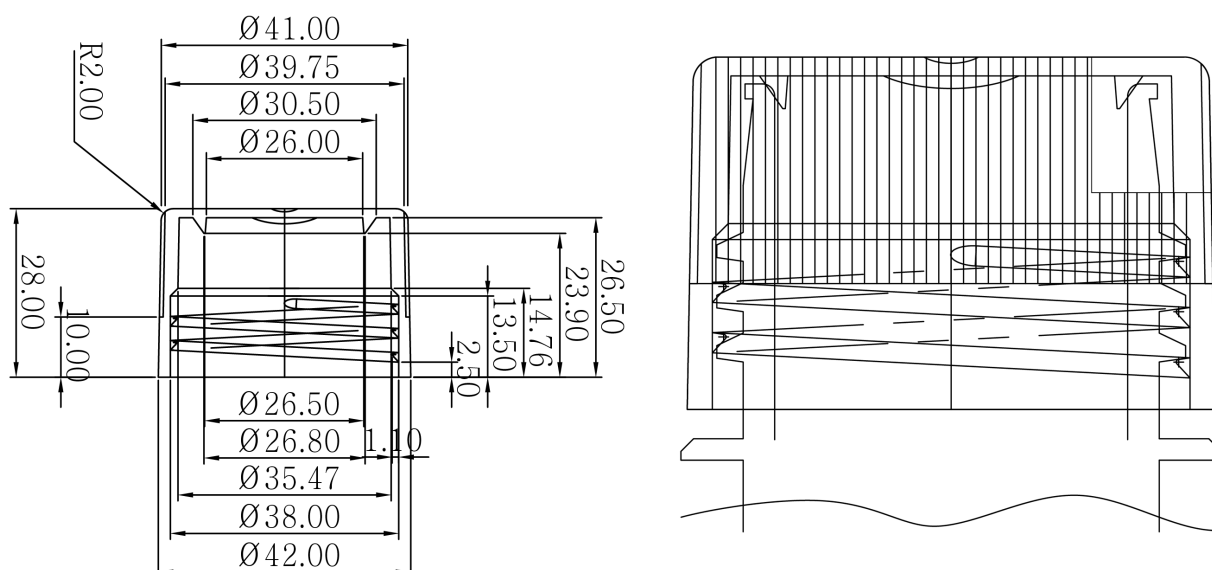

1000ml, Art. 56000



Drawings

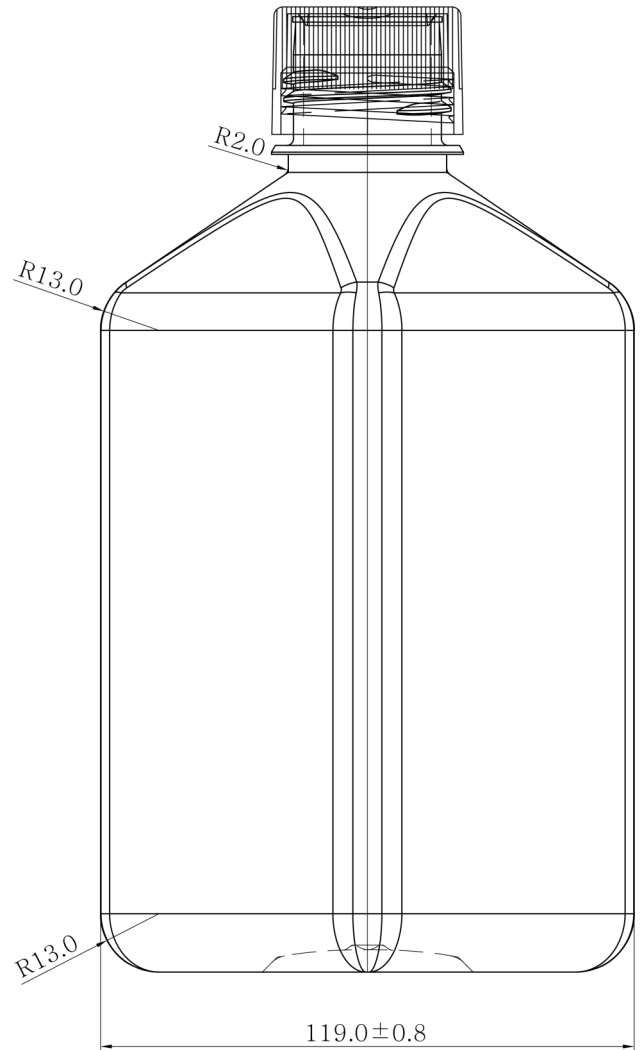
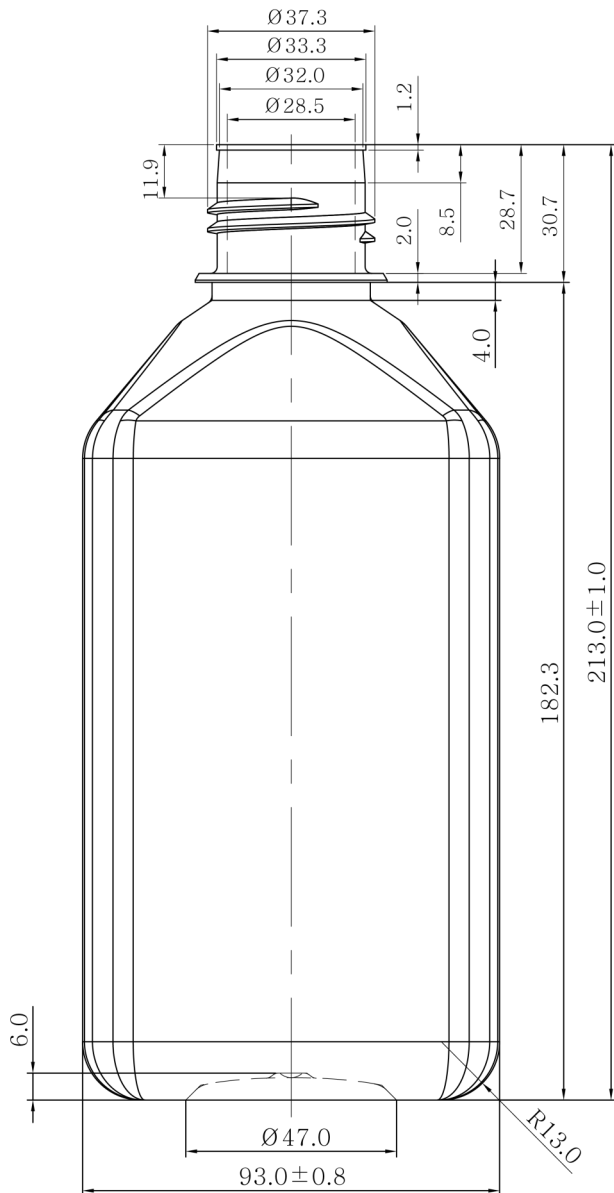

Contact

Bioswisstec Ltd.

Ebnatstrasse 65

8200 Schaffhausen, Switzerland

Contact us: info@bioswisstec.com

Or visit us on our website: www.bioswisstec.com